

# SC5510A

## 20 GHz Signal Source for PXI Express

The SC5510A is a single PXIe Slot, high performance VCO based synthesized signal source with frequency ranging from 100 MHz to 20 GHz. Despite its small single slot PXI form factor, it packs the instrument grade performance of large box instruments. Boasting low phase noise of -115 dBc/Hz @ 10kHz offset from a 10 GHz carrier, tuning the entire band at 1 Hz resolution, and having amplitude step resolution of 0.01 dB over the range of -30 dBm to 10 dBm sets the SC5511A apart from other small modular synthesizers. Furthermore, using a unique multiple phase-locked loop architecture the phase spurs are typically kept below -65dBc across the tuning range, even at 1 Hz step resolution. Furthermore, using a high fundamental frequency VCO (20 GHz) and eliminating multipliers, sub-harmonics due to dividers are typically less than -70dBc and far out spurious signals are also kept below -70 dBc.

The SC5511A has an additional independent RF2 channel whose frequency range covers 100 MHz to 3 GHz with tuning resolution of 25 MHz. This makes the module ideal for both single-stage RF conversion systems, and dual-stage image suppression up/down converter systems. It makes a great general purpose laboratory signal source where demanding low phase noise and signal purity are needed. It is also an ideal choice as an integrated clock source for fast DAC and ADC applications, especially those that require variable sampling rates.



### Product Features

- Low residual phase noise better than -115 dBc/Hz at 20 kHz offset from 10 GHz
- 100 MHz to 20 GHz output range
- 1 Hz tuning resolution (exact frequency)
- < -30 dBm to +10 dBm leveled output
- Spurious signals < -70 dBc typical
- Dual independent channels

### Simplified Functional Diagram

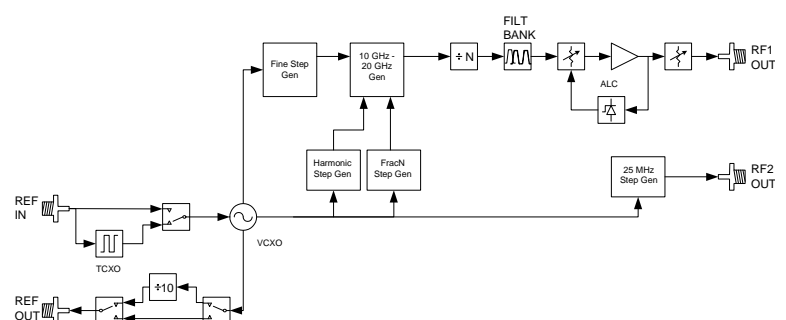

### Application

- RF instrumentation
- Wireless communications
- Signal intelligence
- Data converters
- Software-defined radio

**TECHNICAL SPECIFICATIONS** (AT 25°C AMBIENT, SINE WAVEFORM)**RF1 SPECTRAL SPECIFICATIONS**

RF output frequency range .....	100 MHz to 20 GHz
Internal reference	
Stability <sup>1</sup> .....	±200 ppb
Aging .....	< 1 ppm after 1 year
Phase locking range .....	±5 ppm
Tuning	
Resolution .....	1 Hz
Speed (settled to 1 ppm) <sup>2</sup> .....	< 500 us

Sideband phase noise <sup>3</sup> (dBc/Hz)

Offset	RF Frequency							
	1 GHz		5 GHz		10 GHz		20 GHz	
	typ	max	typ	max	typ	max	typ	max
100 Hz	-80	-74	-66	-60	-60	-54	-54	-48
1 kHz	-122	-116	-108	-104	-102	-96	-96	-90
10 kHz	-134	-128	-121	-115	-115	-110	-110	-105
100 kHz	-135	-129	-121	-115	-115	-110	-110	-105
1 MHz	-135	-129	-121	-115	-115	-110	-110	-105
10 MHz	-150	-145	-139	-136	-133	-130	-131	-130
Floor	-152	-145	-150	-144	-147	-145	-145	-145

## Spurious Signals

< 10 MHz offset	
typical .....	-65 dBc
max .....	-55 dBc
> 10 MHz offset	
typical .....	-75 dBc
max .....	-70 dBc

**RF1 AMPLITUDE SPECIFICATIONS**

Output RF range <sup>4</sup> .....	-25 dBm to +13 dBm
Max output .....	> +15 dBm typical
Amplitude resolution .....	0.01 dB
2 <sup>nd</sup> order harmonics (0 dBm) .....	< -20 dBc
Sub-harmonics .....	< 70 dBc typical
Output level accuracy <sup>5</sup> .....	< ±1.0 dB typical

**RF2 SPECIFICATIONS**

RF range .....	100 MHz to 3 GHz
Frequency step resolution .....	25 MHz
Power output .....	5 dBm typical
2 <sup>nd</sup> order harmonics (0 dBm) .....	< -15 dBc
Phase Noise @ 1 GHz	
1 kHz .....	-110 dBc/Hz
10 kHz .....	-118 dBc/Hz
100 kHz .....	-118 dBc/Hz
1 MHz .....	-142 dBc/Hz
10 MHz .....	-160 dBc/Hz

**TERMINAL SPECIFICATIONS**

RF output terminals	
Impedance .....	50 Ω
Connector type .....	SMA female
Coupling .....	AC
Reference input terminal	
Impedance .....	50 Ω
Connector type .....	SMA female
Coupling .....	AC
Frequency .....	10 MHz
Amplitude range .....	-5 dBm to +10 dBm
Lock range .....	±5 ppm
Reference output terminal	
Impedance .....	50 Ω
Connector type .....	SMA female
Coupling .....	AC
Frequency .....	10/100 MHz
Amplitude .....	+3 dBm typ
PXI 10 MHz clock output terminal	
Impedance .....	50 Ω
Connector type .....	MCX
Coupling .....	AC
Frequency .....	10 MHz
Communication interface .....	PXI Express

**ENVIRONMENTAL**

Operating temperature <sup>6</sup> .....	-10 °C to +55 °C
Operating relative humidity .....	10% to 90%, non-condensing
Operating shock .....	30g, half-sine pulse, 11 ms duration
Operating vibration .....	5 Hz to 500 Hz, 0.31 g <sub>rms</sub>
Altitude .....	2000 m max (maintaining 25 °C ambient temperature)

**GENERAL SPECIFICATIONS**

Power consumption .....	+12 V @ 1.6 A
.....	+3.3 V @ 0.2 A
Weight .....	1 lb
Dimensions (W x H x D, max envelope) .....	0.8" x 5.1" x 7.2"
Warranty .....	1 year parts and labor on defects in materials or workmanship

**ORDER INFORMATION**

7100044-01A .....	SC5510A, 20 GHz Signal Source PXI Express Interface
-------------------	--

Specifications are subject to change without notice. For the most recent product specifications, please visit [www.signalcore.com](http://www.signalcore.com).

- (1) Internal reference is a TCXO. For better accuracies and stability SignalCore recommends phase-locking to a precision external source.
- (2) For step change of less than 100 MHz and only when automatic amplitude adjustment is turned off.
- (3) Specified for channel RF 1 at power levels of greater than 0 dBm.
- (4) Output leveled range is typically -30 dBm to +13 dBm for frequencies < 18 GHz. The leveled range is typically -30 dBm to +10 dBm for frequencies > 18 GHz.
- (5) Output levels < -22 dBm, may degrade to ±2.0 dB typical at some frequencies.
- (6) The PXIe chassis must be capable of cooling 30W per module slot under these temperatures.