

6 GHz Direct IQ Demodulator for PXI Express

The SC5312A is a single slot, 3U, PXI Express, 400 MHz to 6 GHz direct IQ demodulator, downconverting RF directly to analog In-phase (I) and Quadrature (Q) IF or IQ baseband components. The frequency range of the baseband/IF output is DC to 160 MHz. The module can also be operated as a single stage downconverter. The DC-coupled differential IQ pair may be fed to any dual channel digitizer for analog to digital data conversion. The local oscillator (LO) is supplied by any external signal source capable of tuning over the range of the SC5312A (like the SignalCore SC5505A dual channel signal source). The SC5312A can daisy-chain the LO signal, allowing a single source module to drive multiple direct IQ downconverters for coherent reception.

The SC5312A has an auxiliary RF input port that may be connected to the auxiliary RF output port of SignalCore IQ modulators like the SC5412A to aid with system digital equalization that corrects for IQ impairments associated with the device(s). The user can access internal correction DACs, applying compensation offsets to improve the demodulator linearity, IP2, DC offsets, and common mode output voltage of the differential ports. The input compression-to-noise dynamic range is typically 150 dB with noise figure less than 10 dB. IMD is less than -70 dBc for a -20 dBm input signal.

The SC5312A is designed to be paired with the SC5505A signal source to form a complete RF direct IQ demodulator/downconverter solution. It can also be configured with the SC5412A direct IQ upconverter as the core of an RF signal transceiver. The SC5312A's high dynamic range, along with its compact size, low power consumption, and modular flexibility make it attractive for system integration into applications such as wireless device testing, software defined radio research, point-to-point radio, multichannel coherent systems, and other academic and military programs.



Product Features

- RF range 400 MHz to 6 GHz
- DC to 160 MHz baseband
- Noise floor < -165 dBm/Hz
- Input IP3 > 15 dBm
- DC offset calibration
- Adjustable gain > 60 dB
- Compact size

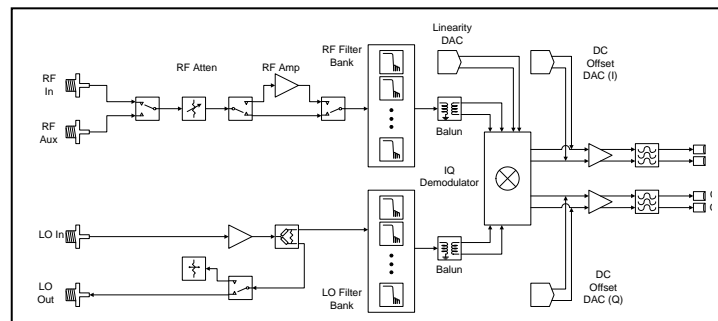

SC5312A Simplified Block Diagram

Applications

- RF instrumentation
- Wireless communications
- Broadcast monitoring
- Spectral analysis
- Software-defined radio

SC5312A SPECIFICATIONS

TECHNICAL SPECIFICATIONS (AT 25°C AMBIENT, SINE WAVEFORM)

SPECTRAL SPECIFICATIONS

RF input frequency range 400 MHz to 6 GHz
 IF output frequency DC to 160 MHz

AMPLITUDE SPECIFICATIONS

Input RF range -160 dBm to +20 dBm
 Max input (with 20 dB RF attenuation) +27 dBm
 RF attenuation range 0 to 60 dB
 RF attenuation resolution 1 dB
 Gain range -30 dB to +30 dB typical
 Input P1dB compression +5 dBm
 IMD3 (two tones, 1 MHz apart)
 (RF amplifier/attenuator adjusted for 1V peak baseband)

Frequency	RF=-10 dBm	RF=-20 dBm	RF=-30dBm
900 MHz	-75 dBc	-80 dBc	-85 dBc
1800 MHz	-70 dBc	-75 dBc	-80 dBc
5800 MHz	-60 dBc	-65 dBc	-67 dBc

Input IP2 > 60 dBc
 Input noise density
 (adjusted for 1V peak baseband)

Frequency	RF = -10 dBm	RF = -30 dBm	Max gain
900 MHz	-148 dBm/Hz	-161 dBm/Hz	-166 dBm/Hz
1800 MHz	-148 dBm/Hz	-161 dBm/Hz	-165 dBm/Hz
5800 MHz	-140 dBm/Hz	-160 dBm/Hz	-160 dBm/Hz

LO leakage at RF port < -70 dBm
 LO level -3 dBm to +3 dBm

QUADRATURE SPECIFICATIONS

Gain mismatch (user equalization not applied)

Frequency	Error
900 MHz	< 0.2 dB
1800 MHz	< 0.2 dB
3600 MHz	< 0.3 dB
5800 MHz	< 0.3 dB

Phase error (user equalization not applied)

Frequency	Error
900 MHz	< 0.6 deg
1800 MHz	< 0.8 deg
3600 MHz	< 2.2 deg
5800 MHz	< 2.0 deg

TERMINAL SPECIFICATIONS

RF and LO input terminals
 Impedance 50 Ω
 Connector type SMA female
 Coupling AC
 Baseband / IF output terminals
 Impedance (single ended) 50 Ω
 Connector type MCX female
 Coupling DC
 Amplitude 2 V max
 Communication interface PXI Express
 Power consumption +12 V @ 0.5 A
 +3 V @ 0.3 A
 Weight 1 lb
 Dimensions (W x H x D, max envelope) 0.8" x 5.1" x 7.2"
 Warranty 1 year parts and labor on
 defects in materials or workmanship

ADDITIONAL FEATURES

- Auxiliary RF port for calibration use
- Switchable LO output
- DAC control for linearity optimization, DC voltage offset, and common differential output voltage
- Switchable RF amplifier to improve SNR for low-level RF signals
- User EEPROM for storage of calibration constants and settings
- Onboard temperature sensor to monitor temperature variation

ORDER INFORMATION

7100029-01 SC5312A, 6 GHz Direct IQ
 Downconverter for PXI Express

Specifications are subject to change without notice. For the most recent product specifications, please visit www.signalcore.com.

- (1) All units are factory calibrated and calibration is stored in onboard EEPROMs. The user must apply the calibration correction to the IF signal for output level accuracy to be valid
- (2) Only with sine-tone generation. Accuracies are limited by the step attenuation resolution
- (3) Shown in the table are two different settings; one set for improved SNR, the other set for improved 3rd order IMD

6 GHz Direct IQ Demodulator Core Module

The SC5313A is a 400 MHz to 6 GHz direct IQ demodulator, downconverting RF signals directly to analog In-phase (I) and Quadrature (Q) IF or IQ baseband components. The frequency range of the baseband/IF output is DC to 160 MHz. The module can also be operated as a single stage downconverter. The DC-coupled differential IQ pair may be fed to any dual channel digitizer for analog to digital data conversion. The local oscillator (LO) is supplied by any external signal source capable of tuning over the range of the SC5313A (like the SignalCore SC5506A dual channel signal source). The SC5313A can daisy-chain the LO signal, allowing a single source module to drive multiple direct IQ downconverters for coherent reception.



The SC5313A has an auxiliary RF input port that may be connected to the auxiliary RF output port of SignalCore IQ modulators such as the SC5413A to aid with system digital equalization that corrects for IQ impairments associated with the device(s). The user can access internal correction DACs, applying compensation offsets to improve the demodulator linearity, IP2, DC offsets, and common mode output voltage of the differential ports. The input compression-to-noise dynamic range is typically 150 dB with noise figure less than 10 dB. IMD is less than -70 dBc for a -20 dBm input signal.

The SC5313A is designed to be paired with the SC5506A signal source to form a complete RF direct IQ demodulator/downconverter solution. It can also be configured with the SC5413A direct IQ upconverter as the core of an RF signal transceiver. The SC5313A's high dynamic range, along with its compact size, low power consumption, and modular flexibility make it attractive for system integration into applications such as wireless device testing, software defined radio research, point-to-point radio, multichannel coherent systems, and other academic and military programs.

Product Features

- RF range 400 MHz to 6 GHz
- DC to 160 MHz baseband
- Noise floor < -165 dBm/Hz
- Input IP3 > 15 dBm
- DC offset calibration
- Adjustable gain > 60 dB
- Compact size

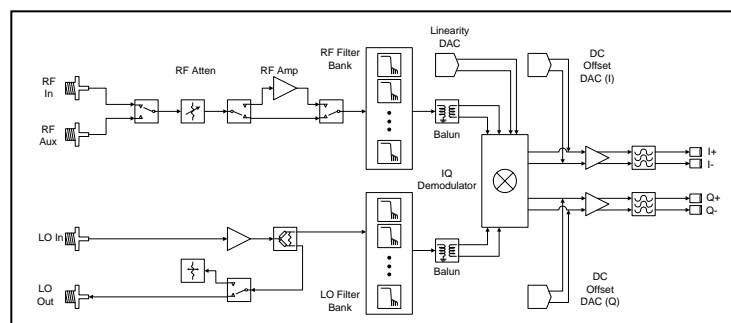

SC5313A Simplified Block Diagram

Applications

- RF instrumentation
- Wireless communications
- Broadcast monitoring
- Spectral analysis
- Software-defined radio

SC5313A SPECIFICATIONS

TECHNICAL SPECIFICATIONS (AT 25°C AMBIENT, SINE WAVEFORM)

SPECTRAL SPECIFICATIONS

RF input frequency range 400 MHz to 6 GHz
 IF output frequency DC to 160 MHz

AMPLITUDE SPECIFICATIONS

Input RF range -160 dBm to +20 dBm
 Max input (with 20 dB RF attenuation) +27 dBm
 RF attenuation range 0 to 60 dB
 RF attenuation resolution 1 dB
 Gain range -30 dB to +30 dB typical
 Input P1dB compression +5 dBm
 IMD3 (two tones, 1 MHz apart)
 (RF Amp/attenuator adjusted for 1V peak baseband)

Frequency	RF=-10 dBm	RF=-20 dBm	RF=-30dBm
900 MHz	-75 dBc	-80 dBc	-85 dBc
1800 MHz	-70 dBc	-75 dBc	-80 dBc
5800 MHz	-60 dBc	-65 dBc	-67 dBc

Input IP2 > 60 dBc
 Input noise density
 (Adjusted for 1V peak baseband)

Frequency	RF = -10 dBm	RF = -30 dBm	Max gain
900 MHz	-148 dBm/Hz	-161 dBm/Hz	-166 dBm/Hz
1800 MHz	-148 dBm/Hz	-161 dBm/Hz	-165 dBm/Hz
5800 MHz	-140 dBm/Hz	-160 dBm/Hz	-160 dBm/Hz

LO leakage at RF port < -70 dBm
 LO level -3 dBm to +3 dBm

QUADRATURE SPECIFICATIONS

Gain mismatch (user equalization not applied)

Frequency	Error
900 MHz	< 0.2 dB
1800 MHz	< 0.2 dB
3600 MHz	< 0.3 dB
5800 MHz	< 0.3 dB

Phase error (user equalization not applied)

Frequency	Error
900 MHz	< 0.6 deg
1800 MHz	< 0.8 deg
3600 MHz	< 2.2 deg
5800 MHz	< 2.0 deg

TERMINAL SPECIFICATIONS

RF and LO input terminals
 Impedance 50 Ω
 Connector type SMA female
 Coupling AC
 Baseband / IF output terminals
 Impedance (single ended) 50 Ω
 Connector type MCX female
 Coupling DC
 Frequency 10 MHz
 Amplitude 2 V max
 Communication interface USB / RS-232 / SPI
 Digital interface HDMI type
 Logic type 3.3V HCT (5V tolerant inputs)
 Power consumption 7 W typical
 Weight 0.9 lbs
 Dimensions (W x H x D, max envelope) 0.75" x 3.75" x 5.75"
 Warranty 1 year parts and labor on defects in materials or workmanship

ADDITIONAL FEATURES

- Auxiliary RF port for calibration usage
- Switchable LO output
- DAC control for linearity optimization, DC voltage offset, and common differential output voltage
- Switchable RF amplifier to improve SNR for low level RF signals
- User EEPROM for storage of calibration constants and settings
- Onboard temperature sensor to monitor temperature variation

ORDER INFORMATION

7100030-01 SC5313A, 6 GHz Direct IQ Downconverter Core Module – USB Interface
 7100030-02 SC5313A, 6 GHz Direct IQ Downconverter Core Module – RS-232 Interface
 7100030-03 SC5313A, 6 GHz Direct IQ Downconverter Core Module – SPI Interface

Specifications are subject to change without notice. For the most recent product specifications, please visit www.signalcore.com.

- (1) All units are factory calibrated and calibration is stored in onboard EEPROMs. The user must apply the calibration correction to the IF signal for output level accuracy to be valid.
- (2) Only with sine-tone generation. Accuracies are limited by the step attenuation resolution
- (3) Shown in the table are two different settings; one set for improved SNR, the other set for improved 3rd order IMD